

Hinge wings

for aluminum profiles / panel elements

SPECIFICATION

Types

- Type **AF**: exterior hinge wing
- Type **AN**: exterior hinge wing, with guide step
- Type **IF**: interior hinge wing
- Type **IN**: interior hinge wing, with guide step

Identification no.

- No. **A**: without bores
- No. **C**: with countersunk holes

Aluminum **EL**
anodized, natural color



INFORMATION

GN 2291 Hinge wings can be combined with GN 2290 (see page) bolt sets into individualized hinge versions.
As of a hinge wing length of $l_2 \geq 250$ mm, individual lengths can be realized by shortening the hinge wing given the greater hole spacings.

ACCESSORY

Bolt sets GN 2290 (see page)

ON REQUEST

- other lengths and hole spacings
- other finishes

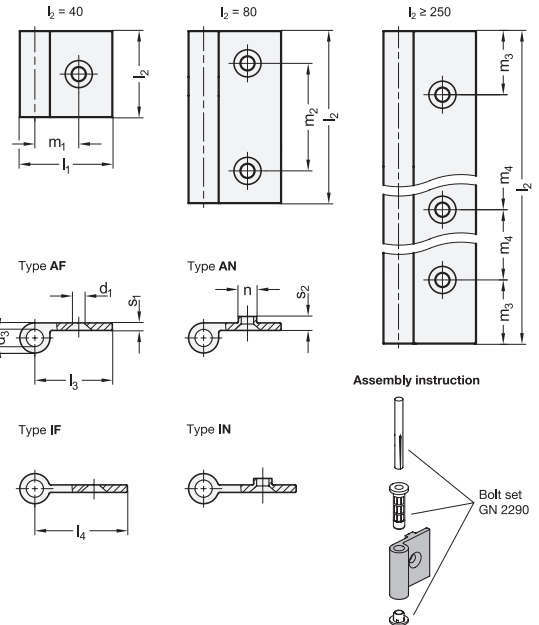

* Complete with Identification no. of the Hinge wings (A or C)

- A** without bores **C** with countersunk holes

GN 2291

Description	l1	l2	d1	d2	d3	l3	l4	m1	m2	m3	m4	n -0.3	s1	s2	⚖
GN 2291-43-40-AN-*-EL	43	40	6.6	14	8	36	-	20.4	-	-	-	8	3.5	6.5	26
GN 2291-43-80-AN-*-EL	43	80	6.6	14	8	36	-	20.4	50	-	-	8	3.5	6.5	52
GN 2291-43-40-AF-*-EL	43	40	6.6	14	8	36	-	20.4	-	-	-	-	3.5	-	23
GN 2291-43-80-AF-*-EL	43	80	6.6	14	8	36	-	20.4	50	-	-	-	3.5	-	47
GN 2291-43-250-AF-*-EL	43	250	6.6	14	8	36	-	20.4	-	50	150	-	3.5	-	146
GN 2291-43-400-AF-*-EL	43	400	6.6	14	8	36	-	20.4	-	50	150	-	3.5	-	233
GN 2291-50-40-IF-*-EL	50	40	6.6	14	8	-	43	27.5	-	-	-	-	3.5	-	25
GN 2291-50-80-IF-*-EL	50	80	6.6	14	8	-	43	27.5	50	-	-	-	3.5	-	50
GN 2291-50-250-IF-*-EL	50	250	6.6	14	8	-	43	27.5	-	50	150	-	3.5	-	155
GN 2291-50-400-IF-*-EL	50	400	6.6	14	8	-	43	27.5	-	50	150	-	3.5	-	249
GN 2291-50-40-IN-*-EL	50	40	6.6	14	8	-	43	27.5	-	-	-	8	3.5	6.5	27
GN 2291-50-80-IN-*-EL	50	80	6.6	14	8	-	43	27.5	50	-	-	8	3.5	6.5	55

Weight Identification no. A

